



# TOYO LED ELECTRONICS LIMITED

Unit 10-11, 19/F, Metro Loft, 38 Kwai Hei Street, Kwai Chung, N.T., Hong Kong  
Tel : (852) 2540 7288 Fax : (852) 2517 1797  
http://www.toyo-led.com E-mail : sales@toyo-led.com



## P/N: TY-L3020UR1(1.3)

3020Package3.0\*2.0mm TOP SMD Series

### ✧ Features:

- 3.0\*2.0\*1.3mm
- Mono-color type
- Soldering methods :All SMT assembly methods
- Comply ROHS standard

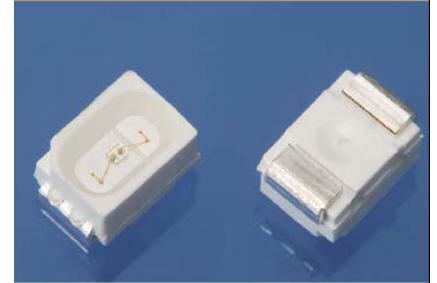

### ✧ Description

The Red source color devices are made with InGaN on sapphire Light Emitting Diode.

### ✧ Application

- Optical indicator
- Indicator and backlighting in telephone and fax
- Flat backlight for LCD, switch and symbol
- Light pipe application
- General use

### ✧ Package Dimensions

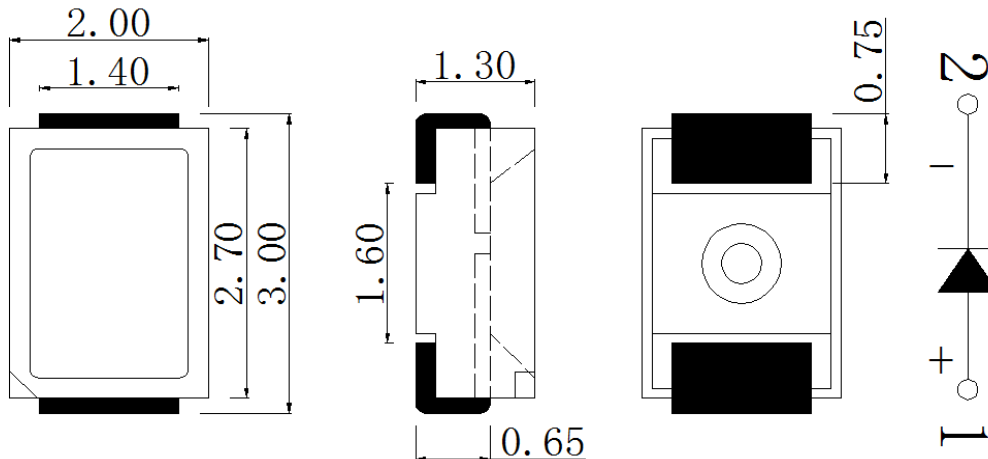

### NOTES:

1. All dimensions are in millimeter[unit];
2. Tolerance is  $\pm 0.1\text{mm}$  ( $0.004''$ ) unless other specified;
3. Specifications are subject to change without notice.



# TOYO LED ELECTRONICS LIMITED

Unit 10-11, 19/F, Metro Loft, 38 Kwai Hei Street, Kwai Chung, N.T., Hong Kong

Tel : (852) 2540 7288

http://www.toyo-led.com

Fax : (852) 2517 1797

E-mail : sales@toyo-led.com



## P/N: TY-L3020UR1(1.3)

3020Package3.0\*2.0mm TOP SMD Series

Part No.	Emitted Color	Lens Color	Chip Material
TY-L3020UR1(1.3)	Red	Water Clear	AlGaInP

### ◇ Absolute Maximum Ratings(Ta=25°C)

Item	Symbol	Maximum	Unit
Power Dissipation	PD	65	mW
Continuous Forward Current	I <sub>Fmax</sub>	30	mA
Peak Forward Current(1/10 Duty Cycle 0.1ms Pulse Width)	I <sub>FP</sub>	100	mA
Reverse Voltage	V <sub>R</sub>	5	V
Operating Temperature Range	T <sub>opr</sub>	-35 to+85	°C
Storage Temperature Range	T <sub>stg</sub>	-40 to+100	°C
Lead Solder Temperature	T <sub>sol</sub>	Reflow Soldering : 260 °C for 5 sec. Hand Soldering : 350 °C for 3 sec.	

### ◇ Electrical/Optical Characteristics(Ta=25°C)

Item	Symbol	Condition	Min.	Typ.	Max	Unit
Forward Voltage	V <sub>F</sub>	I <sub>F</sub> =20mA	1.8	2.1	---	V
Luminous Intensity	I <sub>v</sub>	I <sub>F</sub> =20mA	80	110	---	mcd
Dominant Wavelength	λ <sub>d</sub>	I <sub>F</sub> =20mA	620	630	---	nm
Viewing Angle	2θ <sub>1/2</sub>	I <sub>F</sub> =20mA	---	120	---	Deg
Reverse Current	I <sub>R</sub>	V <sub>R</sub> =5V	---	---	10	uA



# TOYO LED ELECTRONICS LIMITED

Unit 10-11, 19/F, Metro Loft, 38 Kwai Hei Street, Kwai Chung, N.T., Hong Kong  
Tel : (852) 2540 7288 Fax : (852) 2517 1797  
http://www.toyo-led.com E-mail : sales@toyo-led.com



## P/N: TY-L3020UR1(1.3)

3020Package3.0\*2.0mm TOP SMD Series

### ◆ Typical Electro-Optical Characteristics Curves

FIG. 1 Forward Current Vs. Forward Voltage

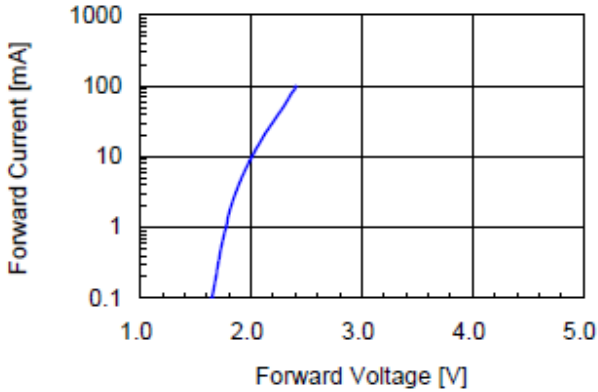

FIG. 2 Relative Intensity Vs. Forward Current

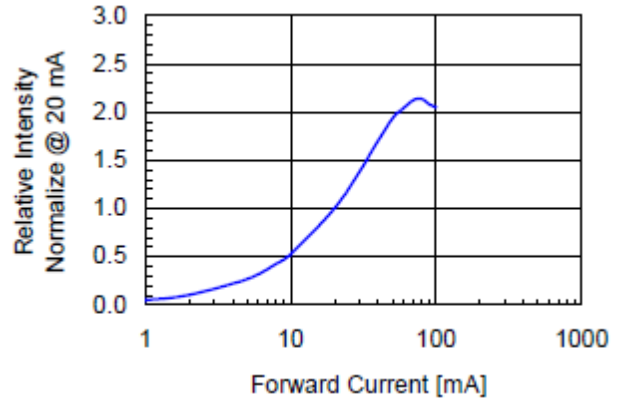

FIG. 3 Forward Voltage Vs. Temperature

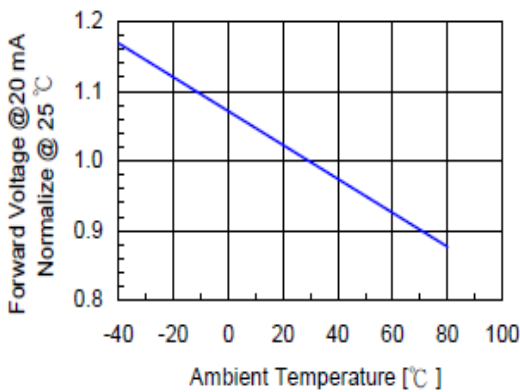

FIG. 4 Relative Intensity Vs. Temperature

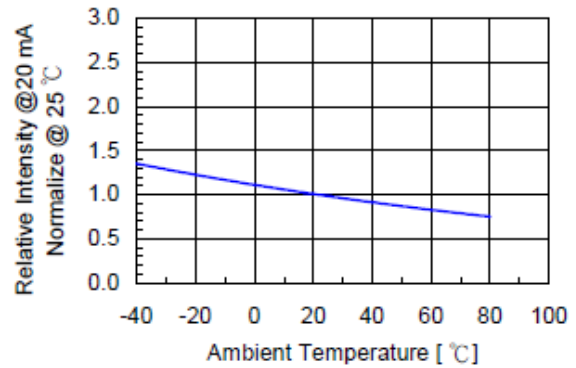
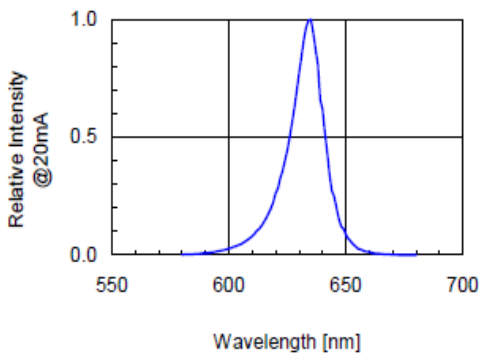

FIG. 5 Relative Intensity Vs. Wavelength





# TOYO LED ELECTRONICS LIMITED

Unit 10-11, 19/F, Metro Loft, 38 Kwai Hei Street, Kwai Chung, N.T., Hong Kong  
 Tel : (852) 2540 7288 Fax : (852) 2517 1797  
 http://www.toyo-led.com E-mail : sales@toyo-led.com



**P/N: TY-L3020UR1(1.3)**

3020Package3.0\*2.0mm TOP SMD Series

## ◇ Reliability Test Items And Conditions

NO.	Item	Test Condition	Test Hr/cycle/time	Sample Q'ty	Ac/Re
1	Reflow	TEMP:260±5°C; Min.5Sec	6 min	22pcs	0/1
2	Temperature Cycle	H:+100°C 30mins To(5mins) L:-40°C 30mins	100cycles	22pcs	0/1
3	Thermal Shock	H:+100°C 15mins L:-40°C 15mins	500 cycles	22pcs	0/1
4	Low Temperature Storage	TEMP:-40°C	1000hrs	22pcs	0/1
5	DC Operating Life	IF=20MA	1000hrs	22pcs	0/1
6	High Temperature High Humidity	85°C 85%R.H.	1000hrs	22pcs	0/1

## ◇ SMT Reflow Soldering Instructions

Number of reflow process shall be than 2 times and cooling Process to normal temperature is required between first and second soldering process

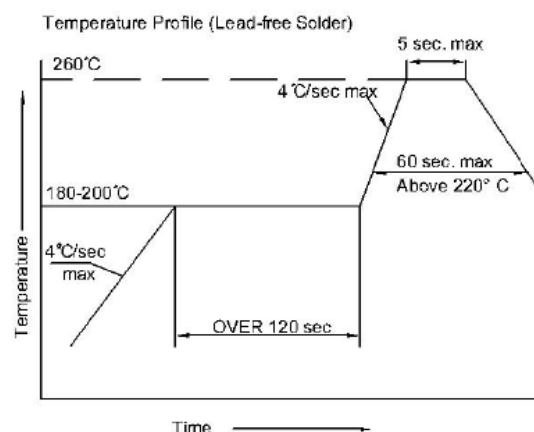
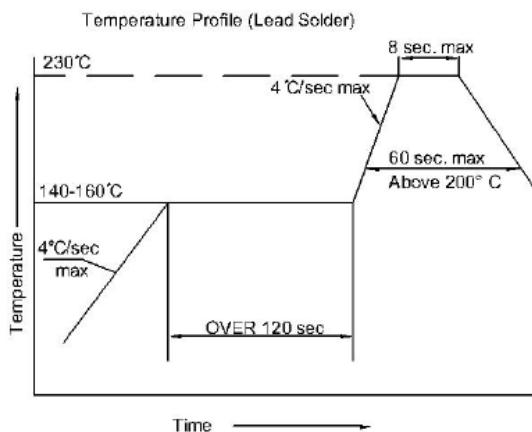



# TOYO LED ELECTRONICS LIMITED

Unit 10-11, 19/F, Metro Loft, 38 Kwai Hei Street, Kwai Chung, N.T., Hong Kong  
Tel : (852) 2540 7288 Fax : (852) 2517 1797  
http://www.toyo-led.com E-mail : sales@toyo-led.com



P/N: TY-L3020UR1(1.3)

3020Package3.0\*2.0mm TOP SMD Series

### Recommended Soldering Pad Dimensions

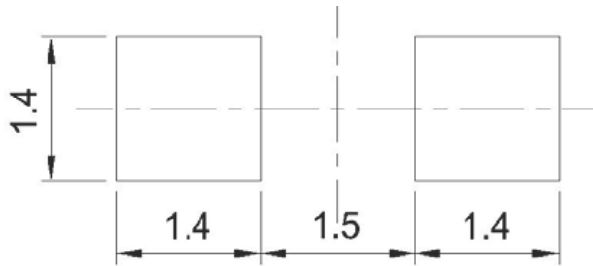

### Tape Specification: 3,000pcs/Reel

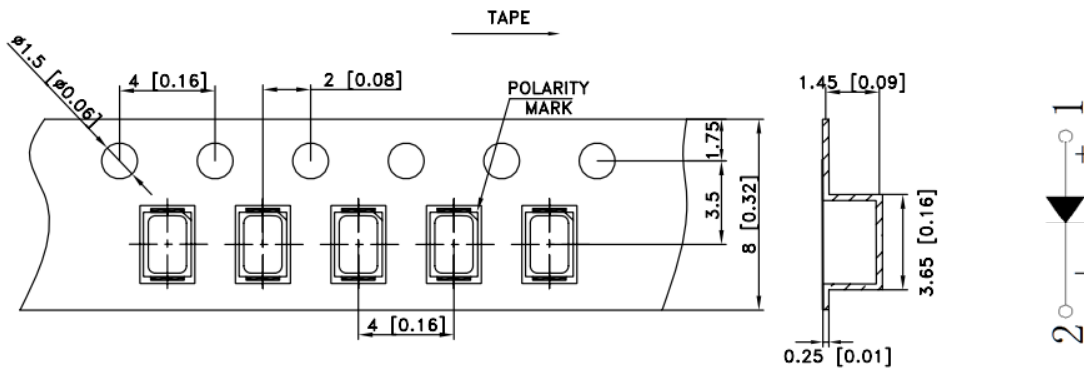
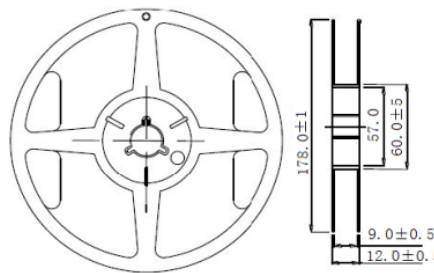

### Package Label

SMD LED	
PART NO: _____	QA Pass
LOT NO : _____	
Q' TY : _____	
VF : _____ IV : _____	
TC : _____ BIN: _____	Pb
DATE : _____	
TOYO LED ELECTRONICS LIMITED	
Website: <a href="http://www.toyo-led.com">http://www.toyo-led.com</a> E-mail: <a href="mailto:sales@toyo-led.com">sales@toyo-led.com</a>	



# TOYO LED ELECTRONICS LIMITED

Unit 10-11, 19/F, Metro Loft, 38 Kwai Hei Street, Kwai Chung, N.T., Hong Kong  
Tel : (852) 2540 7288 Fax : (852) 2517 1797  
http://www.toyo-led.com E-mail : sales@toyo-led.com



**P/N: TY-L3020UR1(1.3)**

3020Package3.0\*2.0mm TOP SMD Series

## ❖ Package & Shipping Instructions

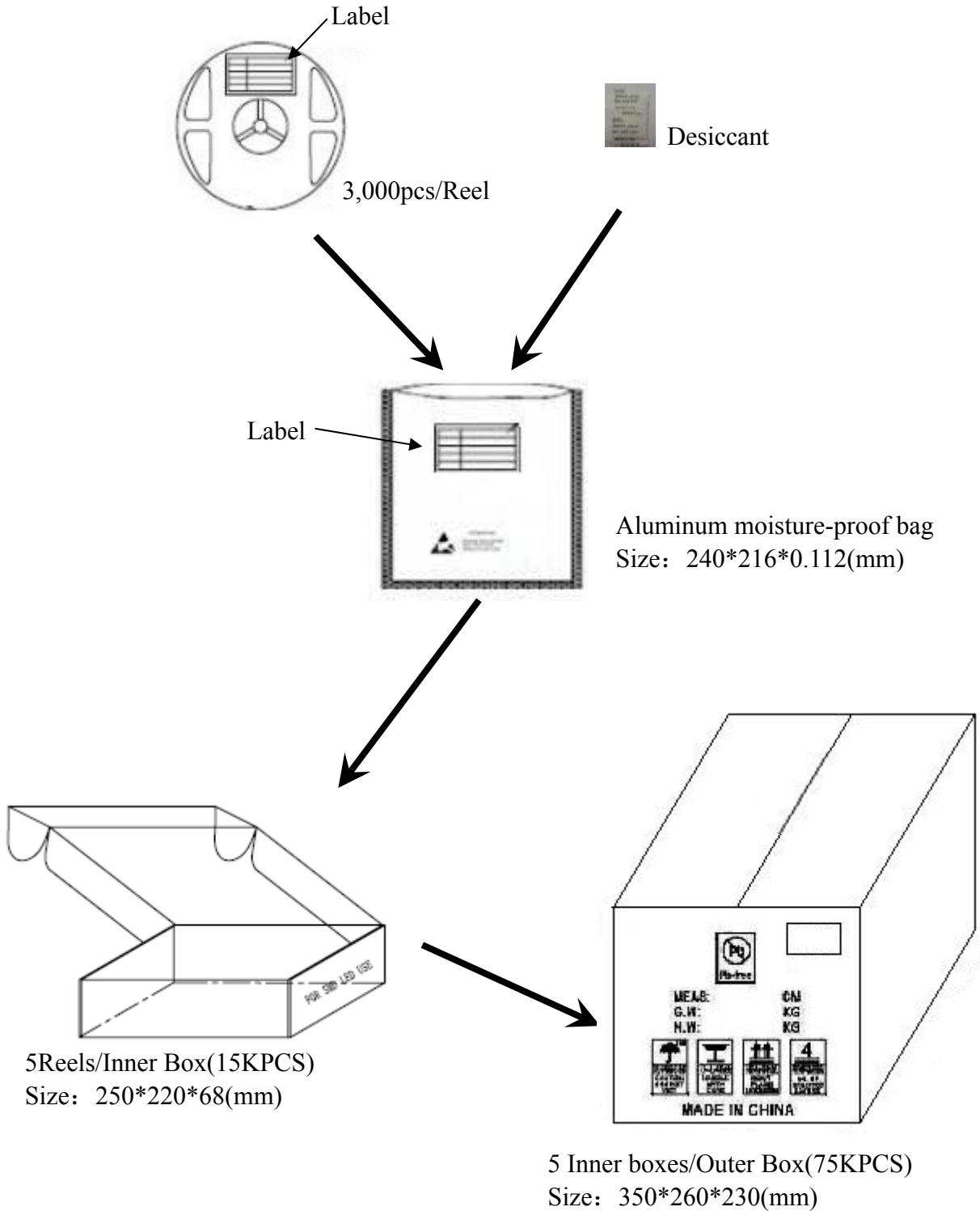



# TOYO LED ELECTRONICS LIMITED

Unit 10-11, 19/F, Metro Loft, 38 Kwai Hei Street, Kwai Chung, N.T., Hong Kong  
Tel : (852) 2540 7288 Fax : (852) 2517 1797  
http://www.toyo-led.com E-mail : sales@toyo-led.com



**P/N: TY-L3020UR1(1.3)**

3020Package3.0\*2.0mm TOP SMD Series

## REVISION HISTORY

DATE	REVISION CONTENTS	VERSION
2018-08-23	New	A