



# TOYO LED ELECTRONICS LIMITED

Room 1610, Hong Kong Plaza, 188 Connaught Road West, Hong Kong.  
 Tel : (852) 2540 7288 Fax : (852) 2517 1797  
 http://www.toyo-led.com E-mail : sales@toyo-led.com



## P/N: TY-30YG1D50-40-T1

3mm Round Type LEDs Series

### PACKAGE DIMENSION

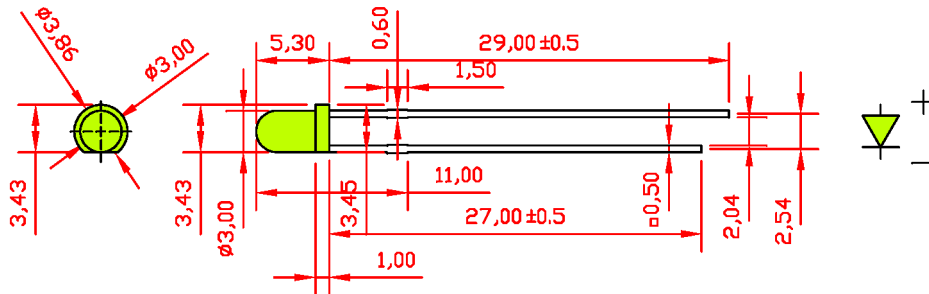

### Selection Guide

Part No.	Dice		Lens Color	( $I_F=20\text{mA}$ )	Viewing Angle ( $2\theta^{1/2}$ )
	Raw Material	Emitted Color		TYP.(mcd)	
TY-30YG1D50-40-T1	GaP	Yellow Green	Green Diffused	40	50°

### Absolute Maximum Ratings( $T_a=25\text{C}^\circ$ )

Item	Symbol	Maximum	Unit
Power Dissipation	$P_D$	78	mW
Peak Forward Current (1/10 Duty Cycle 0.1ms Pulse Width)	$I_{FP}$	150	mA
Continuous Forward Current	$I_{Fmax}$	30	mA
Reverse Voltage	$V_R$	5	V
Capacitance	C	20	pF
Operating / Storage Temperature Range	$T_{opr} / T_{stg}$	-40°C to +85°C	
Lead Solder Temperature	$T_{sol}$	260°C for 3 seconds	

### Electrical / Optical Characteristics( $T_a=25\text{C}^\circ$ )

Item	Symbol	Min.	Typ.	Max.	Unit	Condition
Peak Wavelength	$\lambda_p$	-	568	-	nm	$I_F=20\text{mA}$
Dominant Wavelength	$\lambda_d$	570	573	574	nm	$I_F=20\text{mA}$
Spectral Line Coordinates	$\Delta\lambda$	-	30	-		$I_F=20\text{mA}$
Forward Voltage	$V_F$	1.90	2.40	2.60	V	$I_F=20\text{mA}$
Reverse Current	$I_R$	-	-	10	uA	$V_R=5\text{V}$

#### NOTES:

- All dimensions are in millimeter(inch);
- Tolerance is  $\pm 0.25\text{mm}(0.01\text{'})$  especially other specified; Luminous intensity tolerance is  $\pm 10\%$ ;
- Dominant Emission Wavelength tolerance is  $\pm 5\%$ ; Specifications are subject to change without notice.



## P/N: TY-30YG1D50-40-T1

3mm Round Type LEDs Series

### ■ Typical Electro-Optical Characteristic Curve:

FIG. 1 Forward Current Vs. Forward Voltage

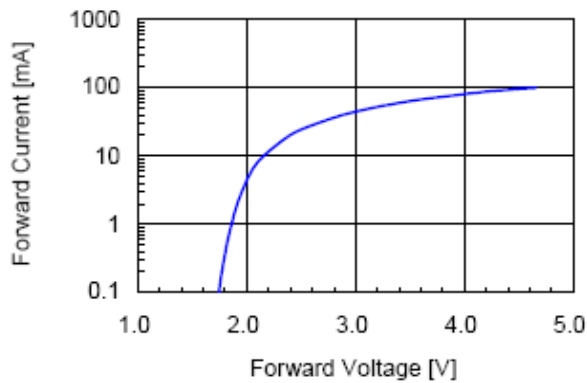

FIG. 2 Relative Intensity Vs. Forward Current

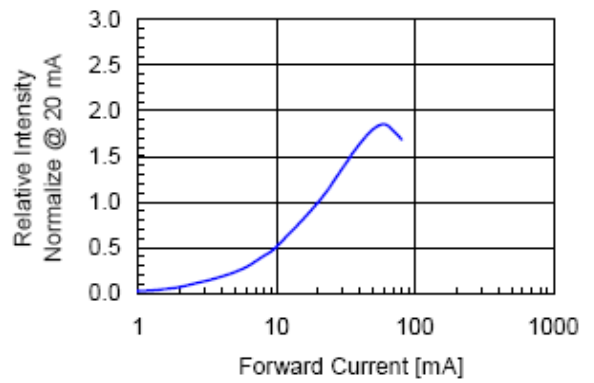

FIG. 3 Forward Voltage Vs. Temperature

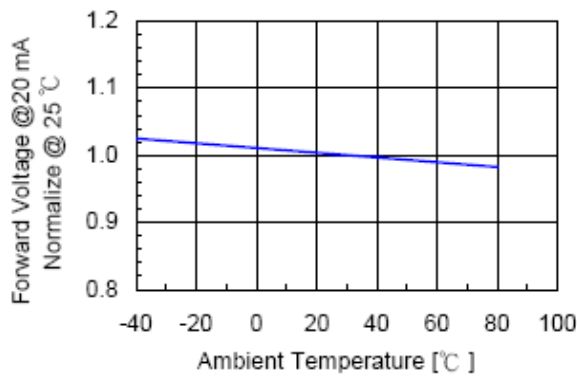

FIG. 4 Relative Intensity Vs. Temperature

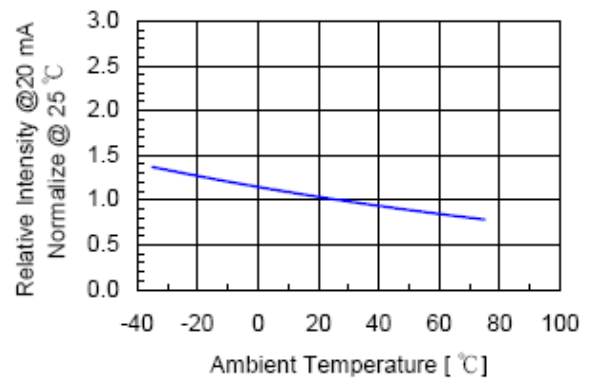
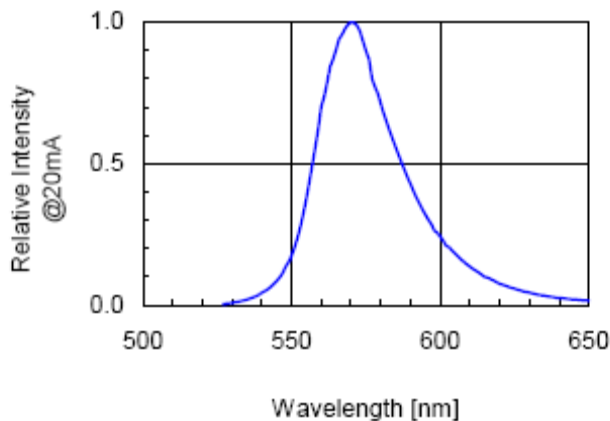

FIG. 5 Relative Intensity Vs. Wavelength





# TOYO LED ELECTRONICS LIMITED

Room 1610, Hong Kong Plaza, 188 Connaught Road West, Hong Kong.

Tel : (852) 2540 7288  
http://www.toyo-led.com

Fax : (852) 2517 1797  
E-mail : sales@toyo-led.com



## P/N: TY-30YG1D50-40-T1

3mm Round Type LEDs Series

### TAPED PACKING

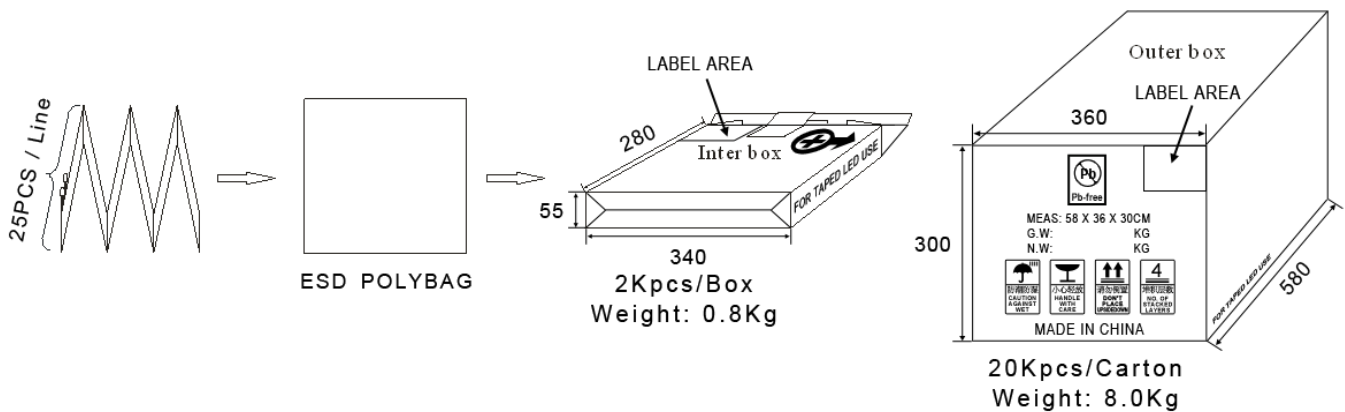
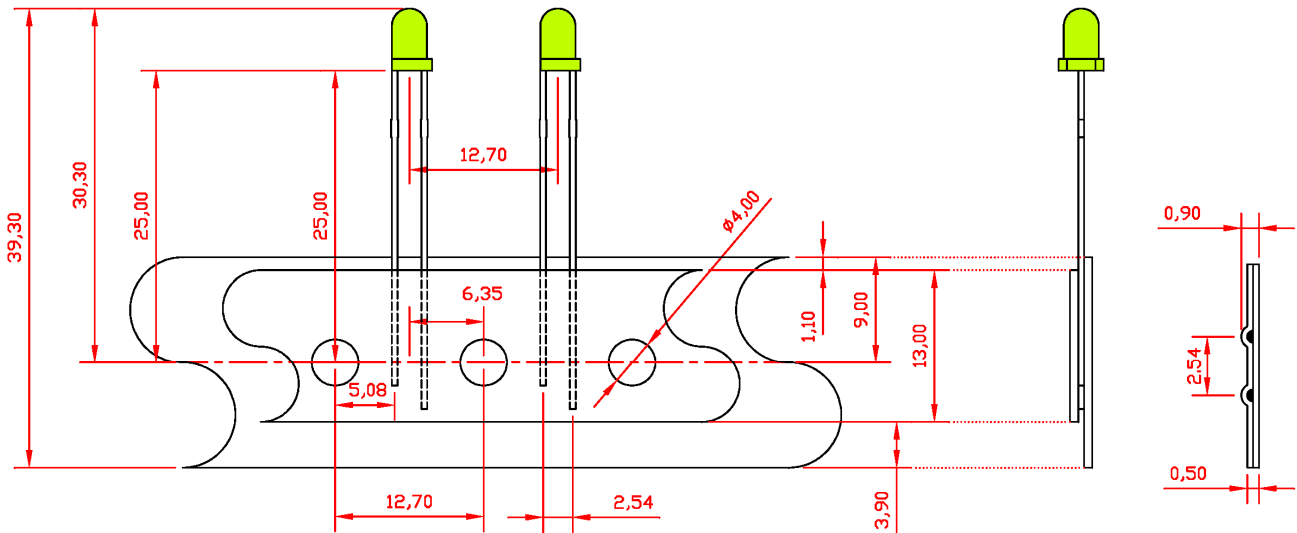

#### Notes:

1. All dimension are in millimeter (inches);
2. Tolerance is  $\pm 0.25\text{mm}$  ( $0.01''$ ) unless otherwise specified.
3. Not recommend to solder within 3mm from the resin.
4. Any kind of LEDs can be made in taped & reel.