



# TOYO LED ELECTRONICS LIMITED

Room 1610, Hong Kong Plaza, 188 Connaught Road West, Hong Kong.  
 Tel : (852) 2540 7288 Fax : (852) 2517 1797  
 http://www.toyo-led.com E-mail : sales@toyo-led.com



## P/N: TY-30UR1D50-150-T1

3mm Round Type LEDs Series

### PACKAGE DIMENSION

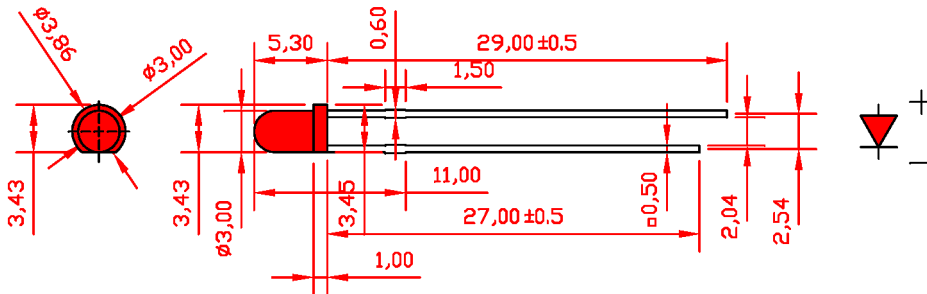

### Selection Guide

Part No.	Dice		Lens Color	(If=20mA)	Viewing Angle (2θ <sup>1/2</sup> )
	Raw Material	Emitted Color		TYP.(mcd)	
TY-30UR1D50-150-T1	AlGaInP	Ultra Red	Red Diffused	150	50°

### Absolute Maximum Ratings(Ta=25C°)

Item	Symbol	Maximum	Unit
Power Dissipation	P <sub>D</sub>	72	mW
Peak Forward Current (1/10 Duty Cycle 0.1ms Pulse Width)	I <sub>FP</sub>	90	mA
Continuous Forward Current	I <sub>Fmax</sub>	30	mA
Reverse Voltage	V <sub>R</sub>	5	V
Capacitance	C	95	pF
Operating / Storage Temperature Range	T <sub>opr</sub> / T <sub>stg</sub>	-40°C to +85°C	
Lead Solder Temperature	T <sub>sol</sub>	260°C for 3 seconds	

### Electrical / Optical Characteristics(Ta=25C°)

Item	Symbol	Min.	Typ.	Max.	Unit	Condition
Peak Wavelength	λ <sub>p</sub>	-	640	-	nm	I <sub>F</sub> =20mA
Dominant Wavelength	λ <sub>d</sub>	627	632	637	nm	I <sub>F</sub> =20mA
Spectral Line Coordinates	Δλ	-	25	-		I <sub>F</sub> =20mA
Forward Voltage	V <sub>F</sub>	1.80	2.00	2.40	V	I <sub>F</sub> =20mA
Reverse Current	I <sub>R</sub>	-	-	10	uA	V <sub>R</sub> =5V

#### NOTES:

- All dimensions are in millimeter(inch);
- Tolerance is ±0.25mm(0.01") especially other specified; Luminous intensity tolerance is ±10%;
- Dominant Emission Wavelength tolerance is ±5%; Specifications are subject to change without notice.



## P/N: TY-30UR1D50-150-T1

3mm Round Type LEDs Series

### ■ Typical Electro-Optical Characteristic Curve:

FIG. 1 Forward Current Vs. Forward Voltage

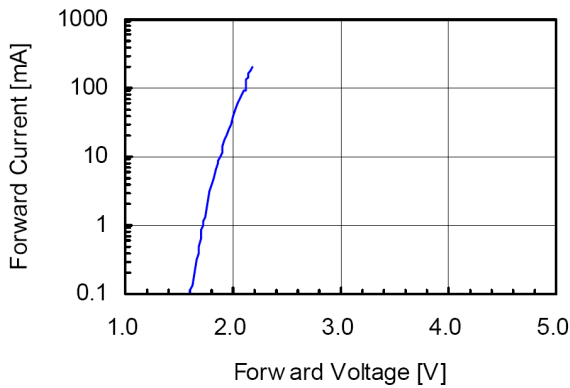

FIG. 2 Relative Intensity Vs. Forward Current

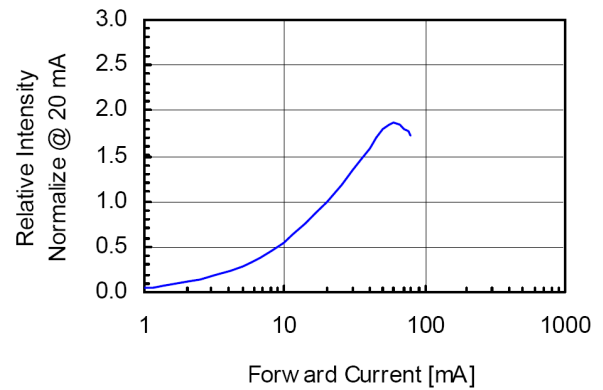

FIG. 3 Forward Voltage Vs. Temperature

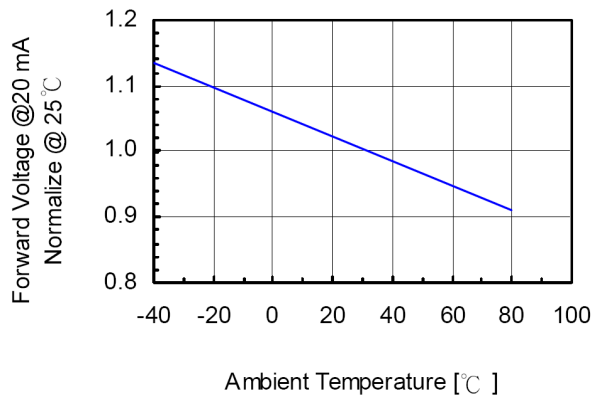

FIG. 4 Relative Intensity Vs. Temperature

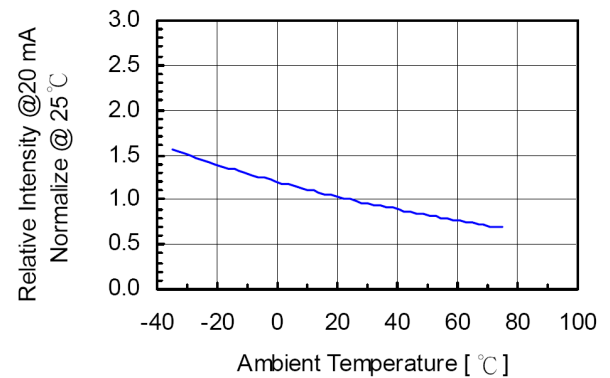
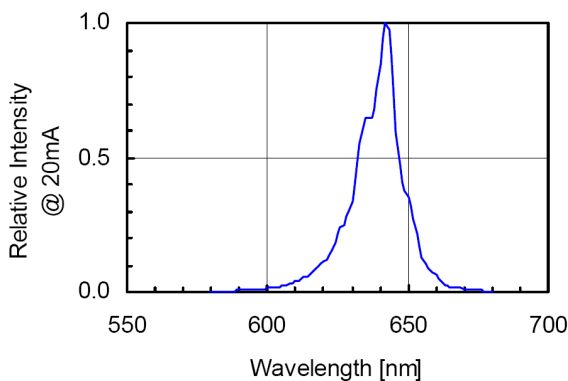

FIG. 5 Relative Intensity Vs. Wavelength





# TOYO LED ELECTRONICS LIMITED

Room 1610, Hong Kong Plaza, 188 Connaught Road West, Hong Kong.

Tel : (852) 2540 7288  
http://www.toyo-led.com

Fax : (852) 2517 1797  
E-mail : sales@toyo-led.com



## P/N: TY-30UR1D50-150-T1

### 3mm Round Type LEDs Series

#### TAPED PACKING

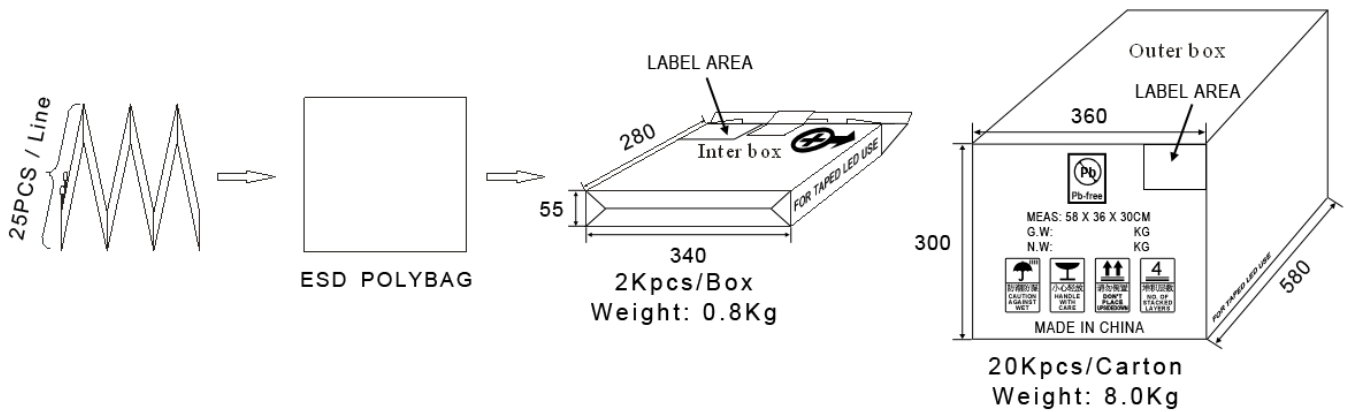
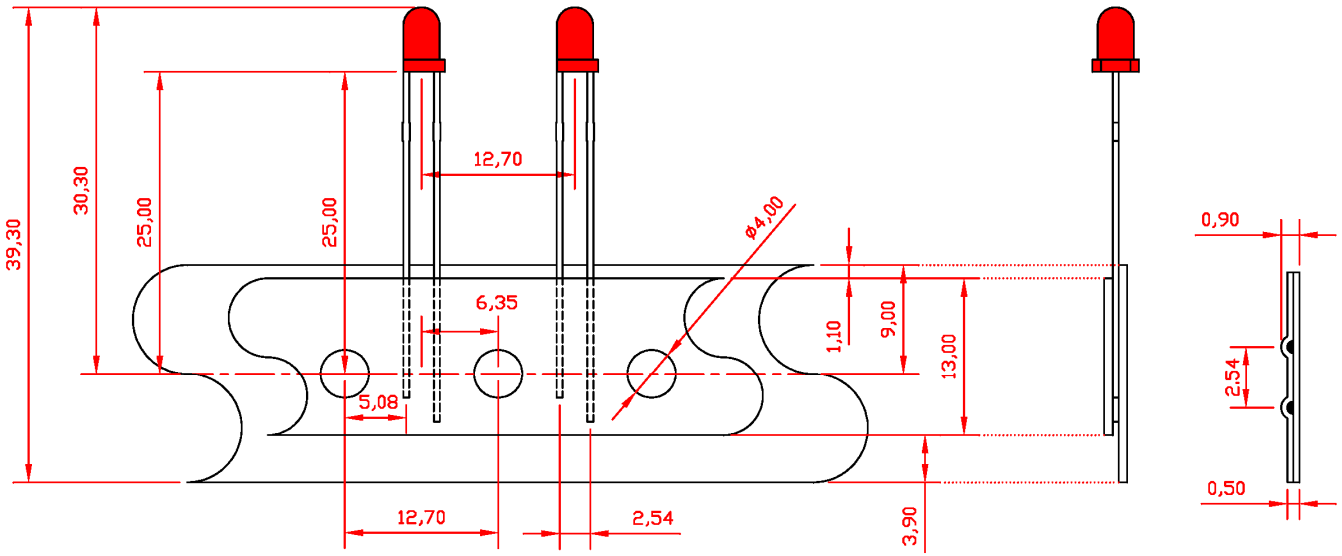

#### Notes:

1. All dimension are in millimeter (inches);
2. Tolerance is  $\pm 0.25\text{mm}$  ( $0.01''$ ) unless otherwise specified.
3. Not recommend to solder within 3mm from the resin.
4. Any kind of LEDs can be made in taped & reel.